

Half Pattern Detail

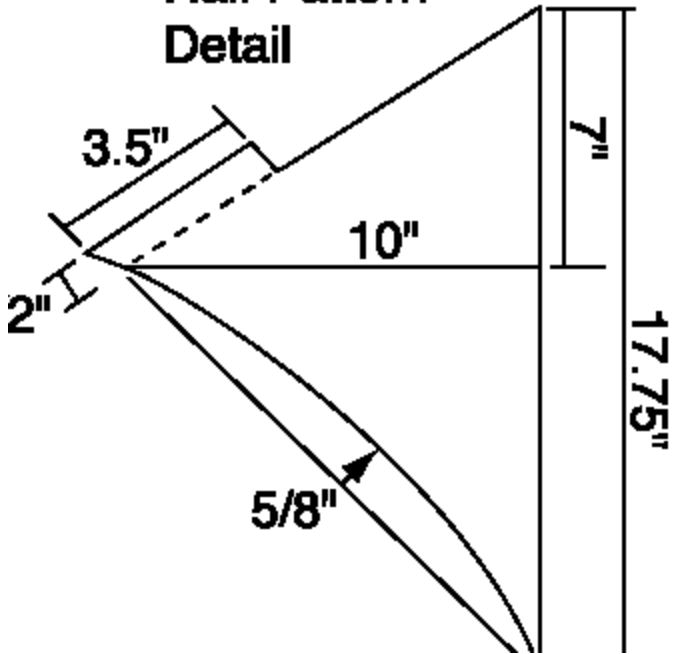

Updated Dragonfly Fighter Plan - Aug 24, 1999
Provided by Tom Humphrey

Kite specifications: 20" wingspan, 17.75" spine length. Line of wingtips bisects the spine 7" from the nose of the kite. Trailing edge should be cut out 5/8" on a smooth curve from wingtip to tail of kite. Bridle attachments are on the bow 1" on either side of the spine, and 9" down the spine from where the bow and spine cross.

Tools and Materials Needed:

Rulers, preferably metal
Curve stick or flexible curve for trailing edge of sail
Wire cutters to trim carbon fiber bow
X-acto knife for cutting Mylar

Needle for threading bridle lines

Clear packaging tape, 2" width

Contact cement

Super glue

Mylar for sail

.050 Carbon fiber rod for bow, 24" long

Bow setter - a bow setter is nothing more than two vinyl end caps joined by a length of line with a line tensioning slider in the middle. This allows you to insert the tips of your rod into the vinyl caps and adjust the curve of the bow to fit your kite.

Bamboo stick for spine - (dowel can be substituted, but if you do, sand or plane the dowel until you have a flat side to it, or to save weight and make shaping easier, sand down two opposing sides of the dowel. If you use a dowel, mark where the wingtip line will be, and put a slight bend in the dowel just in front of it.)

Line for bridle -(I like to use LaserPro 20lb dacron line for bridles; it is strong and waxed along it's entire length)

Poster board for sail pattern template

Create a template out of cardboard or poster board according to the dimensions in the illustration (Half Pattern Detail)

Fold a sheet of Mylar in half and tape it down to your working surface. Place the spine line of your template on the fold, and trace out the sail on the Mylar. Carefully cut the sail out of the Mylar, using a ruler to keep the lines straight. The curve will be tricky, so cut out the curve first. Unfold. This gives you a symmetrical sail. The pattern leaves extra Mylar tabs to fold over the bow. Make a mark along the line of the leading edges to the wingtip and crease the extra Mylar so that there is a straight leading edge from nose to wingtip.

Placement of Holes in Sail

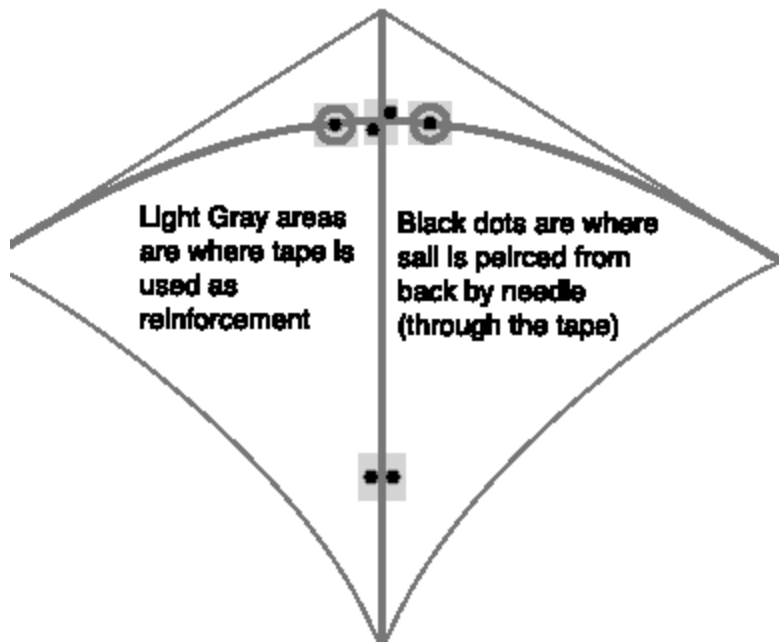

Put a bead of contact cement down the center fold. Put another bead of contact cement on the face of the spine. Stick the spine down onto the fold. Remember, you only get one try, so be as careful as possible.

Put your bow into the bow setter and adjust the tension so that the bow can fit from wingtip to wingtip, without any part of the bow falling outside of the sail area. Place the bow onto the sail (over the spine) and fit into the creases at the wingtips. Note where the bow fits into the creases at the wingtips. This is the area of the bow that you will coat with contact cement. Coat the bow ends with contact cement and carefully put it aside.

Put a bead of contact cement on the sail on the tab crease, and also lightly coat the tabs. Place your bow onto the kite so that the cemented edges of the bow and tabs meet, and fold the tabs over the bow. Smooth the Mylar down over the bow and let the cement dry. There will be a small end of the tab that does not meet the sail; this will be cut away later.

Prepare 4 pieces of packing tape. Two will be 1/2" x 1", and two will be 11" x 1".

When the cement is dry, remove the bow setter. The sail should now be under tension. Clip off the exposed ends of the bow with the wire cutter and cut away the extra Mylar left over from the tab. Use the 1/2" x 1" pieces of tape and fold them around the ends of the bow as extra protection from the bow poking through. This is unlikely; but the tape helps to reinforce. Place the 11" x 1" tape onto your work surface sticky side up. Carefully place the leading edge of the kite halfway onto the tape from wingtip towards the nose. The tape will not reach all the way to the nose of the kite. This is intended to enclose the leading edge and bow at the wingtips. Burnish the back of the leading edge so that the tape is smooth on the front edge of the kite. Fold the tape over the leading edge and the bow ends and smooth it down to the back of the kite.

Prepare a 2" x 4" piece of packing tape. Place the tape sticky side up on your work surface and place the nose of the kite over the tape so that the ends of the 4" side just meet the leading edges of the sail. Smooth the tape down over the front of the sail. This should cover the ends of the tape used to stiffen and reinforce the leading edge. There will be a section of tape exposed. Cut the tape down to the sail edge on either side of the spine and fold this strip over the top of the spine stick. Then carefully fold the tape over the leading edges and smooth it down over the back of the sail, wrapping it over the spine and the strip of tape folded over it. Repeat this process at the tail of the kite. This will be harder to follow with the curved edge of the Mylar, but get as close as you can. The sail is now finished and reinforced.

Measure 1" from the center of the spine where the bow crosses it, and mark the back of the sail where the yoke lines will go through. I place a loose-leaf binder reinforcement over the mark to limit how far the Mylar can tear. For extra reinforcement, place a small square of tape over the

binder reinforcement. Cut a 1" x 1" piece of packing tape and wrap it over the spine between the yoke line marks. This will reinforce the point where the bow is tied to the sail.

Measure 9" down from where the bow crosses the spine and make a mark. Place a 1" x 1" piece of tape over the spine with the mark at the center and wrap it over the spine. This will be the lower bridle point.

Push a needle through the tape at the back of the sail on either side of the spine next to the lower bridle point, and on either side of the spine where the bow crosses it (One hole below the bow on one side, and the other above the bow on the other). Then push a needle through the sail at the yoke line points. Care has to be taken to get beneath the bow.

See the sail hole detail.

Thread a line through the cover where the bow crosses the spine, and tie the bow to the spine, leaving the knot at the back above the bow.

Thread the yoke line through one of the holes made 1" from the spine. Tie the line to the bow. Thread the other end of the yoke line through the other hole. Pull the line through until the center of the yoke line is 4" above the front of the sail and tie off the other side. The yoke line is now ready.

Tie a small overhand loop in a longer length of line, and put the end of the line through the loop twice in a double larkshead knot around the yoke line. Tighten the knot to the center of the yoke line, and thread the other end through the holes at the lower bridle point. Pull this tight. Pull the line back through the cover to the yoke point, and then pull the line past this point about the width of two to three fingers. Tie the lower bridle knot at the base of the kite. This gives you the proper bridle lengths. Tie a tow loop out of the excess bridle line and attach it to the bridle with a double larkshead knot. Turn the kite over and coat the line with super glue where it attaches to the bow and spine. This keeps the knots from slipping and possibly tearing the sail.

Carefully put a slight bend in the bamboo spine from about the wingtip line forward.

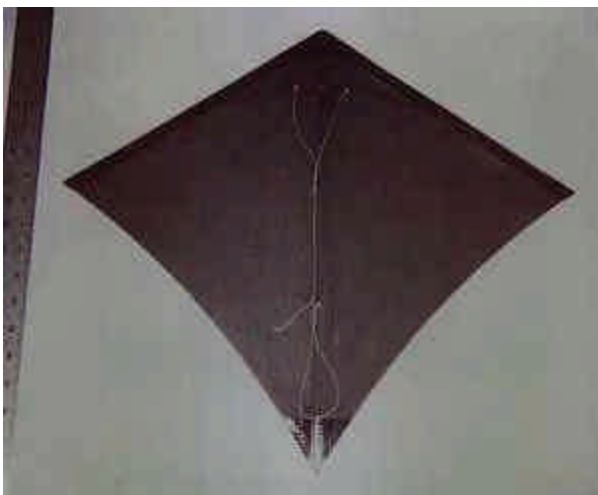

Congratulations! You are ready to tune and fly your new Dragonfly!